

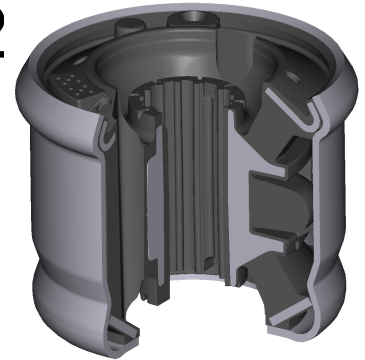

## “DURABUSH” Generation 2 Patented Hydraulic Bush

Vertical or horizontal fix, hydraulically damped, high durability bush - multiple suspension applications. High amplitude decoupling and dynamic tuning via patented “nose” features. High load capability, **45kN**.



Static Y Stiffness (Damping Direction)

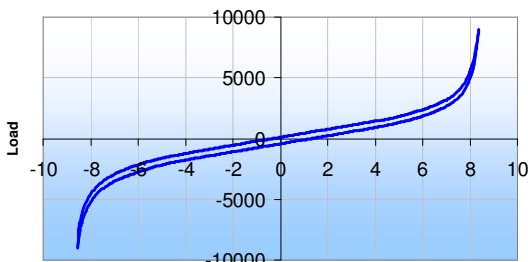

Loss angle Y 0.1mm

### Static Stiffness :

X: Non - Damped 600N/mm (300-850)

Y: Damped 600N/mm (300-850)

Z: Axial 1825N/mm (1100-3000)

### Loss Angle tuning Y Direction:

7 – 20Hz

### Applications:

- Control arm
- Differential mountings
- Gearbox mounting
- Subframe mounting

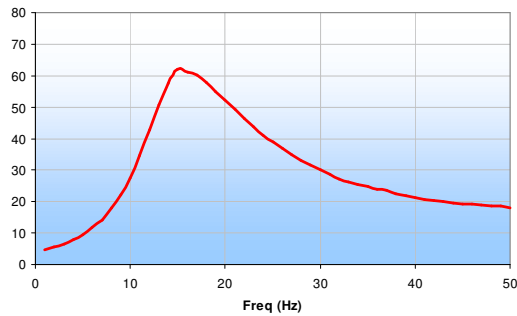

Dynamic stiffness Y 0.1mm

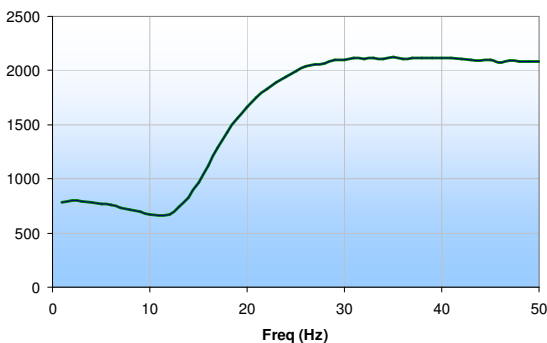

Dynamic Stiffness at 15Hz  
Y Direction

